

DC Motor Controlling and Simulation Through 3-Phase Thyristor based-Inverter

Syed Atif Naseem¹, Riaz Uddin², Syed Wasif Naseem³, Athar Rashid⁴

^{1,4} Department of Electrical & Electronics Engineering, Department of Political Sciences & IR

Izmir University of Economics

Izmir, 35330, Turkey (syedatifnaseem@gmail.com, athar.gs@gmail.com) * Corresponding author

^{2,3} Department of Electrical Engineering, NED University of Engineering and Technology
 Karachi, 75290, Pakistan (riaz.uddin@neduet.edu.pk)

Abstract: Separately excited DC motor with variable speed can be controlled through three phase inverter by applying firing delay angle alpha of 0-90 degree. In this paper, we modeled the DC motor in MATLAB simulation by utilizing the angular acceleration and current derivative equation. Moreover, modeling of bridge rectifier along with thyristors is also constructed in MATLAB simulation scenario and generated the controlling result of DC motor speed at different thyristor delay angle.

Keywords: DC motor, Thyristor, Bridge rectifier, MATLAB.

I. INTRODUCTION

Brushless DC motor is an ideal and widely implemented DC motor for industrial application due to its high torque, though small in size and retains higher efficiency. DC motor speed with brushless carbon can be controlled by applying a novel method as studied in [1, 2]. The researchers studied the DC motor mathematical model in MATLAB by designing the PID discrete controller and current controller with the help of pulse width modulation inverter in order to analyze the consumption of current, which will not exceed the maximum current while running of DC motor at full torque or by varying its speed. Similarly [3, 4] design the fuzzy logic controller which depends on genetic algorithm and the two different loops of method have been applied on brushless DC motor to control its torque.

In this research paper, we have studied and analyzed the DC motor along with 3 phase inverter in order to control its variable speed by ensuring that the maximum current consumption of motor will not exceed the rated current value of the DC motor.

A Dc motor is a general actuator in the control system and its drives the rotary motion or translational motion depending upon the application by connecting it with wheels/drum or cables. The input voltage is applied to the DC motor armature in order to provide a rotary motion of the shaft $d(\theta)/dt$.

The physical parameters of DC motor are as follows:

- Moment of inertia of motor 0.01 kg.m² (J)
- Motor viscous friction constant 0.1 N.m.s (b)
- Electromotive force constant 0.01 V/rad/sec (Ke)
- Motor torque constant 0.01 N.m/Amp (Kt)
- Electric resistance 1 ohm (R)
- Electric Inductance 0.5 H (L)

In DC motor, the torque is directly proportional to the armature current as indicated in equation 1, while the motor torque constant is developed through magnetic field strength.

$$T = K_t i \rightarrow \text{eq}(1)$$

Similarly back E.M.F voltage is directly proportional to angular velocity of shaft of motor by a constant factor of K_e as shown in equation 2.

$$E = k_e \omega \rightarrow \text{eq}(2)$$

In SI units, the back E.M.F voltage constant and motor torque constants are equal; therefore instead of using K_t and K_e , we used K for both constants.

The manuscript is organized as follows: Section 2 briefly explains the DC motor modeling. Section 3 is dedicated to the inverter modeling i.e., bridge rectifier with Thyristors. Section 4 explains the simulation result of DC motor along with inverter by firing at different delay angle of thyristor. Finally, Section 5 concludes the research article by highlighting the key contribution of the manuscript.

II. DC MOTOR MODELING

Applying the Kirchoff's laws on armature circuit, the integrals of rotational acceleration and the armature current rate change is given in equation 3 and equation 4

$$\int \frac{d^2\theta}{dt^2} dt = \frac{d\theta}{dt} \rightarrow \text{eq}(3)$$

$$\int \frac{di}{dt} dt = i \rightarrow \text{eq}(4)$$

Now with the application of the Newton's law to the motor system the following equations will be generated in order to make the state space model and then this DC motor model will be simulated in the MATLAB tool.

$$J \frac{d^2\theta}{dt^2} - b \frac{d\theta}{dt} = \frac{d^2\theta}{dt^2} = 1/J(K_t i - b \frac{di}{dt}) \rightarrow \text{eq}(5)$$

$$L \frac{di}{dt} = -Ri + V - e = \frac{di}{dt} = 1/L(-Ri + V - K_e \frac{d\theta}{dt}) \rightarrow \text{eq}(6)$$

The equation 5 represents the angular acceleration which is equal to $1/J$ multiplied by sum of two terms i.e; positive and negative, where b represents the motor friction constant. Similarly, the current derivative is equal to $1/L$ multiplied by sum of one positive and two negative terms. The model of DC motor is shown in fig 1.

III. MODELING OF 3 PHASE TYRISOTR BASED BRIDGE RECTIFIER

The 3 phase bridge rectifier is shown in fig. 2

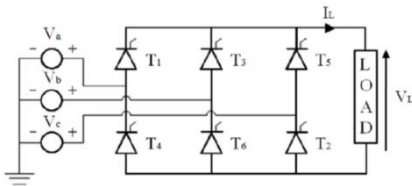

Fig. 2 Three phase bridge rectifier

provides the signal to two of the thyristor at the same time with firing delay angle α . These two thyristor control the output load by supplying the required current to the load.

IV. SIMULATION RESULT OF DC MOTOR AND INVERTER

In this section, the two models which are constructed in section 2 and section 3 have been integrated in order to analyze the whole system by controlling the torque of DC motor and applying the delay firing angle on inverters. The output result contains thyristor output

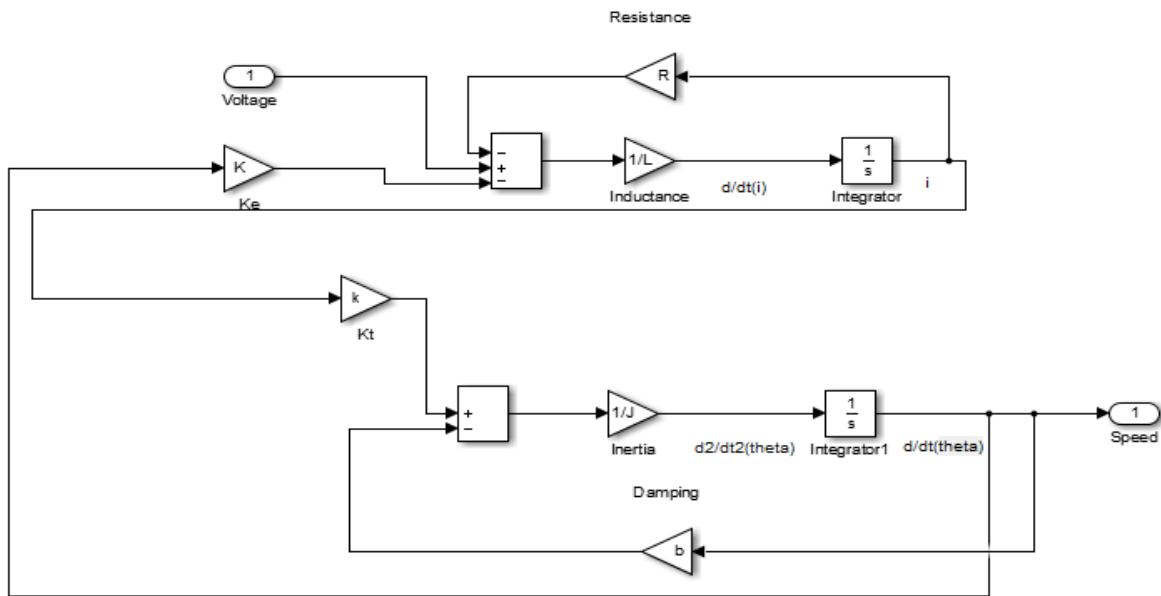

Fig. 1 DC motor Model

Where $\theta = \omega t$
 $V_a = E \cdot \sin(\theta)$
 $V_b = E \cdot \sin(\theta + 120)$
 $V_c = E \cdot \sin(\theta - 120)$
 And T1-T6 are thyristors.

Only two thyristors are in operational, at the same time by giving the firing delay angle of pulse α as shown in table below:

Range of θ	Thyristor in Operation
$\alpha + 30$ to $\alpha + 90$	T1 and T6
$\alpha + 90$ to $\alpha + 150$	T1 and T2
$\alpha + 150$ to $\alpha + 210$	T2 and T3
$\alpha + 210$ to $\alpha + 270$	T3 and T4
$\alpha + 270$ to $\alpha + 330$	T4 and T5
$\alpha + 330$ to $\alpha + 360$	T5 and T6

The three phase bridge rectifier model is shown in fig 3. The 6 pulse thyristor generator through de-multiplexer

current and voltage, as well as DC motor speed control at different firing delay angle of thyristor through pulse generator special block.

- At firing delay angle $\theta = 0$, we will get the following thyristor output voltage and current and DC motor speed control

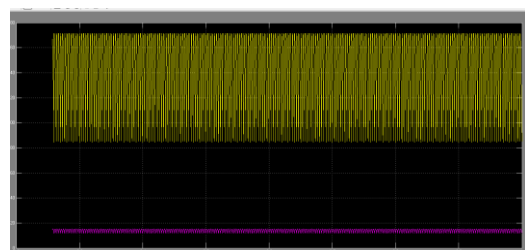

Fig.4 Thyristor Output Voltage and Current at $\theta = 0$

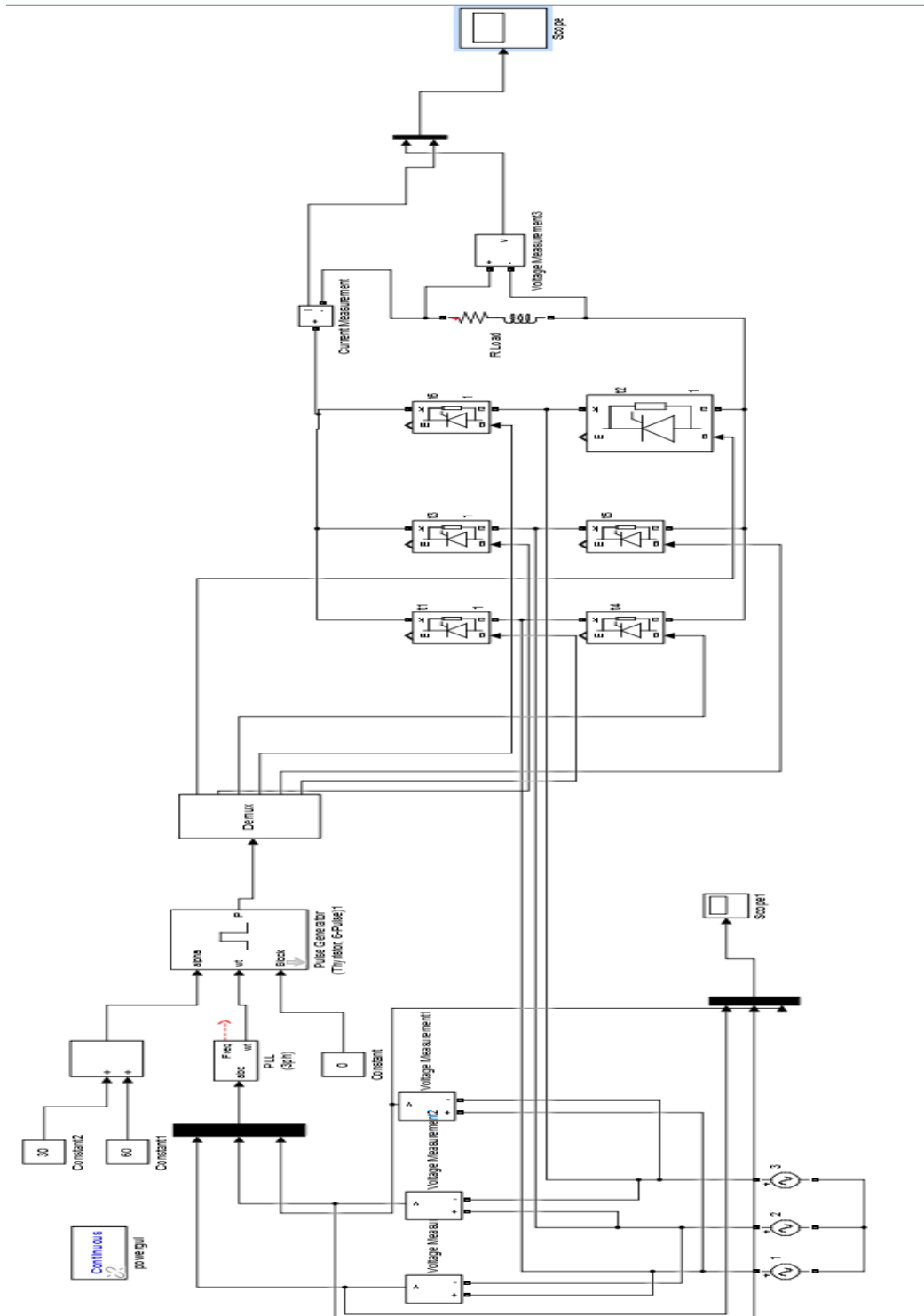

Fig. 3 Three Phase Inverter Model (Thyristor based bridge rectifier)

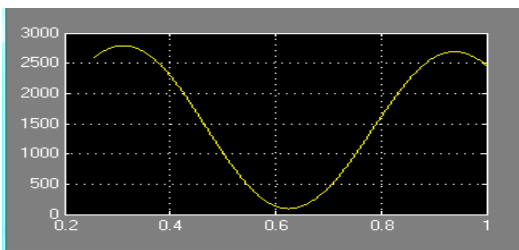

Fig.5 DC motor speed control at $\theta=0$

- At firing delay angle $\theta=30$, we will get the following thyristor output voltage and current

and DC motor speed control

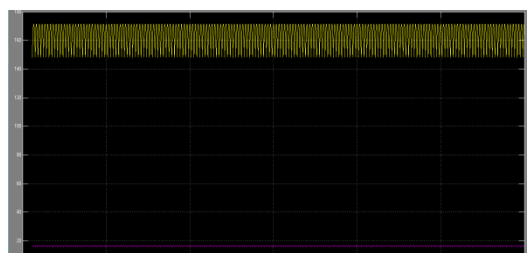

Fig.6 Thyristor Output Voltage and Current at $\theta=30$

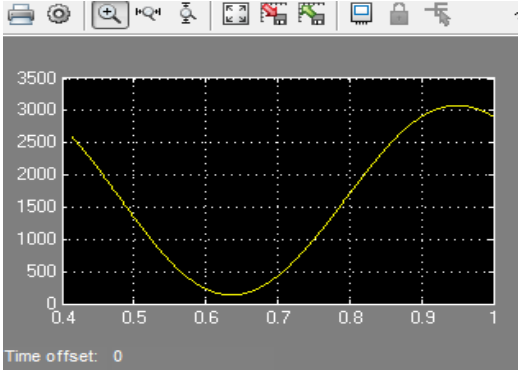

Fig.7 DC motor speed control at $\theta=30$

- At firing delay angle $\theta=60$, we get the following thyristor output voltage and current and DC motor speed control

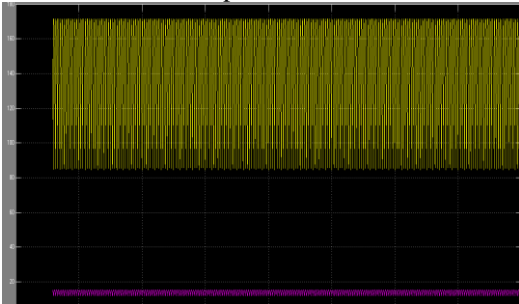

Fig.8 Thyristor Output Voltage and Current at $\theta=60$

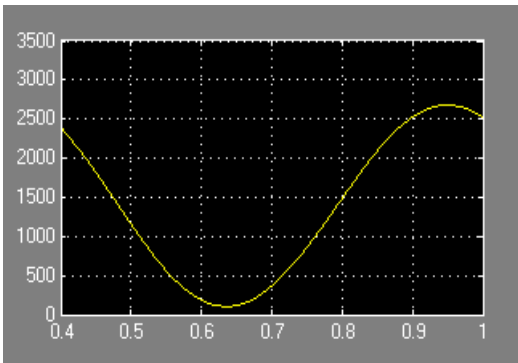

Fig.9 DC motor speed control at $\theta=60$

- At firing delay angle $\theta=90$, we will get the following thyristor output voltage/current and DC motor speed control.

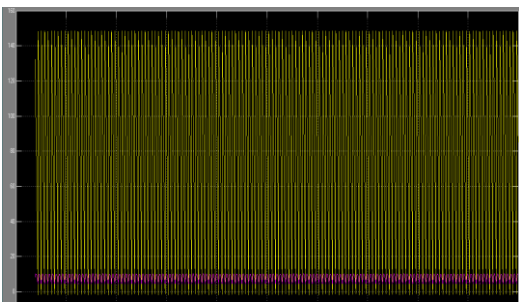

Fig.10 Thyristor Output Voltage and Current at $\theta=90$

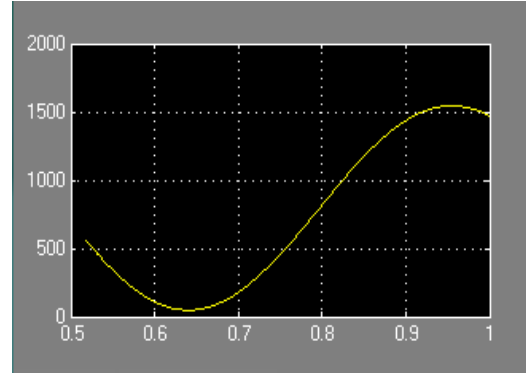

Fig. 11DC motor speed control at $\theta=90$

V. CONCLUSION

The three phase thyristor bridge rectifier is controlled by using special block called pulse generator thyristor- 6 pulse. The synchronized 6 pulse generator takes as input from phase to phase voltages and firing delay angle alpha.

The DC motor model is constructed in MATLAB with the help of angular acceleration and derivative of current equation. Moreover, the 3 phase inverter (Thyristor based bridge rectifier) is also modeled in simulink tool box of MATLAB. In addition, the complete circuit operation of DC motor controlled by thyristor based bridged rectifier is also simulated in MATLAB and result of speed control of DC motor is shown along with the output voltage and current of three phase inverter.

REFERENCES

- [1] Y.-H. Yin, B. Zheng, and H.-X. Zheng, "A Method for Modeling and Simulation of Brushless DC Motor Control System based on Matlab [J]," *Journal of System Simulation*, vol. 2, p. 008, 2008.
- [2] Z.-f. YE and H.-g. LEI, "Simulation of BLDCM control system based on MATLAB [J]," *Electrical Drive Automation*, vol. 1, 2005.
- [3] C. Xia, P. Guo, T. Shi, and M. Wang, "Speed control of brushless DC motor using genetic algorithm based fuzzy controller," in *Proceeding of the 2004 International Conference on Intelligent Mechatronics and Automation, Chengdu, China, 3rd edn. A Treatise on Electricity and Magnetism*, 2004, pp. 68-73.
- [4] W.-l. LUO and J.-c. LIU, "A new approach to the modeling and simulation of brushless DC motors based on fuzzy control," *Computer Engineering & Science*, vol. 8, p. 044, 2009.